

SELF-PROPELLED ARTICULATING BOOMS

Z™-45/25 & Z™-45/25J DC/Bi-Energy

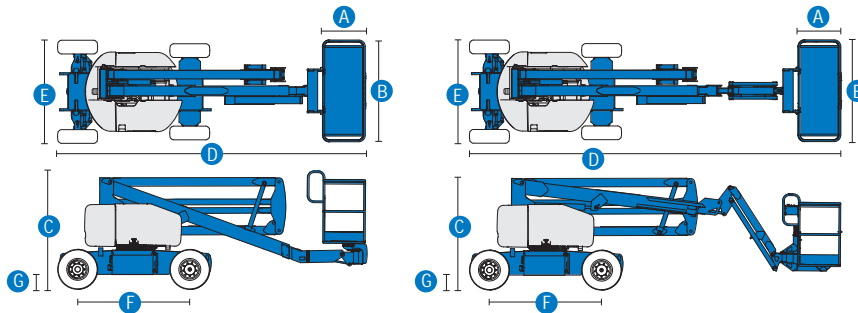

Specifications



MODELS	Z™-45/25 DC & Bi		Z™-45/25J DC & Bi	
MEASUREMENTS	US	Metric	US	Metric
Working height maximum*	51 ft 6 in	15.87 m	51 ft 8 in	15.92 m
Platform height maximum	45 ft 6 in	13.87 m	45 ft 8 in	13.92 m
Horizontal reach maximum	25 ft	7.62 m	25 ft 1 in	7.65 m
Up and over clearance maximum	23 ft 1 in	7.04 m	22 ft 1 in	6.73 m
A Platform length	2 ft 6 in	.76 m	2 ft 6 in	.76 m
B Platform width	6 ft	1.83 m	6 ft	1.83 m
C Height - stowed	6 ft 7 in	2.00 m	6 ft 7 in	2.00 m
D Length - stowed	18 ft 3 in	5.56 m	22 ft 5 in	6.83 m
E Width	5 ft 10.3 in	1.79 m	5 ft 10.3 in	1.79 m
F Wheelbase	6 ft 8 in	2.03 m	6 ft 8 in	2.03 m
G Ground clearance - center	9.5 in	.24 m	9.5 in	.24 m

PRODUCTIVITY

Lift capacity	500 lbs	227 kg	500 lbs	227 kg
Platform rotation	180°		160°	
Vertical jib rotation	—		135°	
Turntable rotation	355° non-continuous		355° non-continuous	
Turntable tailswing	zero		zero	
Drive speed - stowed	3.0 mph	4.8 km/h	3.0 mph	4.8 km/h
Drive speed - raised**	0.68 mph	1.1 km/h	0.68 mph	1.1 km/h
Gradeability - stowed***	30%		30%	
Turning radius - inside	6 ft	1.83 m	6 ft	1.83 m
Turning radius - outside	14 ft	4.26 m	14 ft	4.26 m
Controls	24V DC proportional		24V DC proportional	
Tires	9 x 14.5 in (foam-filled)		9 x 14.5 in (foam-filled)	

POWER

Power source - DC	48V DC (eight 6 V batteries, 350 Ah capacity)			
Power source - Bi-Energy	48V DC (eight 6 V batteries, 350 Ah capacity) with Kubota 12 hp (8.9 kW) diesel driven alternator			
Auxiliary power unit	24V DC		24V DC	
Hydraulic tank capacity	8 gal	30.3 L	8 gal	30.3 L
Fuel tank capacity	9 gal	34.1 L	9 gal	34.1 L

WEIGHT****

DC	15,350 lbs	6,963 kg	16,300	7,394 kg
Bi-energy	15,850 lbs	7,190 kg	16,800	7,620 kg

STANDARDS COMPLIANCE

ANSI A92.5, CSA B354.4, CE Compliance, AS 1418.10

RANGE OF MOTION Z™-45/25

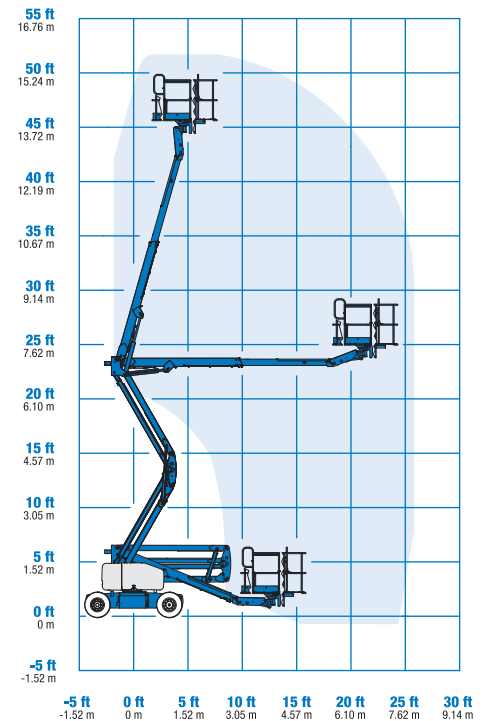

RANGE OF MOTION Z™-45/25J

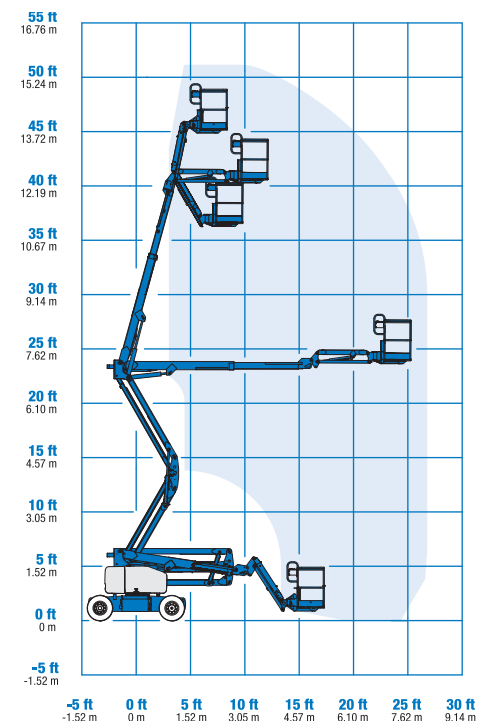

* The metric equivalent of working height adds 2 m to platform height. U.S. adds 6 ft to platform height.
 ** In lift mode (platform raised), the machine is designed to operate on firm, level surfaces only.
 *** Gradeability applies to driving on slopes. See operator's manual for details regarding slope ratings.
 **** Weight will vary depending on options and/or country standards.

Features

EASILY CONFIGURED TO MEET YOUR NEEDS

PLATFORM OPTIONS

- Steel 6 ft (1.83 m) (standard)
- Steel 4 or 5 ft (1.22 or 1.52 m)
- Steel 6 ft (1.83 m) tri-entry

JIB OPTIONS

- Non-jib
- Articulating 5 ft (1.52 m) jib boom

POWER

- 48V DC (eight 6V 350 Ah batteries)

DRIVE

- 2WD

TIRE OPTIONS

- Industrial foam-filled (standard)
- Industrial non-marking foam-filled

STANDARD FEATURES

MEASUREMENTS

Z™-45/25

- 51 ft 6 in (15.87 m) working height
- 25 ft (7.62 m) horizontal reach
- 23 ft 1 in (7.04 m) up and over clearance
- Up to 500 lb (227 kg) lift capacity

Z™-45/25J

- 51 ft 8 in (15.92 m) working height
- 25 ft 1 in (7.65 m) horizontal reach
- 22 ft 1 in (6.73 m) up and over clearance
- Up to 500 lb (227 kg) lift capacity

PRODUCTIVITY

- Self-leveling platform
- Hydraulic platform rotation
- Fully proportional controls
- Thumb rocker steer
- Drive enable
- AC power to platform
- Horn
- Hour meter
- Tilt alarm
- 355° non-continuous turntable rotation
- Zero tailswing

POWER

- 48V deep cycle battery pack
- 24V DC auxiliary power
- 25 Amp 48V on-board charger
- Onboard alternator powered by Kubota 12 hp (8.9 kW) engine (Bi-energy model only)
- Battery charge indicator-BCI (Bi-energy model only)
- Universal 30A battery smart charger

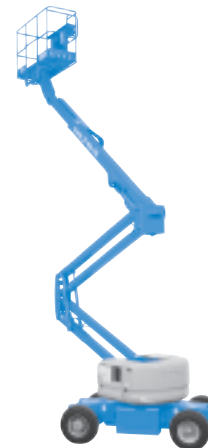

OPTIONS & ACCESSORIES

PRODUCTIVITY

- Platform swing gate
- Half-mesh platform inserts with swing gate
- Platform top auxiliary rail
- Air line to platform
- Fire resistant hydraulic oil
- Biodegradable hydraulic oil
- Standard aircraft protection package*
- Deluxe aircraft protection package*
- Tool tray
- Fluorescent tube caddy
- Pipe cradle (pair)
- Alarm package
- Panel cradle package**
- Platform work lights
- Lockable platform control box cover
- Tow package

POWER

- EE UL583 Fire Protection rating (DC models only)
- Battery charge indicator - BCI (DC only)
- Low voltage interrupt with BCI
- Cold Weather Package (Bi-Energy only)
- Retained key selector switch
- 800 watt inverter

* Reduces platform capacity to 440 lbs (only available on Jib models)

** Requires tri-entry platform

Genie United States

18340 NE 76th Street
P.O. Box 97030
Redmond, Washington 98073-9730

Telephone +1 (425) 881-1800
Toll Free in USA/Canada +1 (800) 536-1800
Fax +1 (425) 883-3475

Genie Europe

Millennium House
Brunel Drive
Newark NG24 2DE
UK

Telephone +44 (0)1476 584333
Fax +44 (0)1476 584334

Email: infoeurope@genieind.com

Distributed By:

Effective Date: January, 2009. Product specifications and prices are subject to change without notice or obligation. The photographs and/or drawings in this document are for illustrative purposes only. Refer to the appropriate Operator's Manual for instructions on the proper use of this equipment. Failure to follow the appropriate Operator's Manual when using our equipment or to otherwise act irresponsibly may result in serious injury or death. The only warranty applicable to our equipment is the standard written warranty applicable to the particular product and sale and we make no other warranty, express or implied. Products and services listed may be trademarks, service marks or trade-names of Terex Corporation, Genie Industries, Inc. and/or their subsidiaries in the U.S.A. and many other countries and all rights are reserved. Terex is a Registered Trademark of Terex Corporation in the U.S.A. and many other countries. Genie is a Registered Trademark of Genie Industries, Inc. in the U.S.A. and many other countries. Genie is a Terex Company. © 2009 Terex Corporation.

Z45DC/BI 3.5K 0109K. Part No. 109361

www.genieindustries.com