



## Self-Propelled Articulating Boom Lifts (Battery Drive)

**Dingli**

**GTBZ12AE**

|  |                                 |                 |
|--|---------------------------------|-----------------|
|  | S.W.L                           | 230kg           |
|  | Max. Occupants                  | 2               |
|  | Max. Working Height             | 12.60m          |
|  | Max. Platform Height            | 10.60m          |
|  | Max. Horizontal Reach           | 6.65m           |
|  | Turntable Tailswing             | 0               |
|  | Up and Over Clearance           | 5.40m           |
|  | A Overall Length (Stowed)       | 6.30m           |
|  | A Overall Length (Transported)  | 6.30m           |
|  | D Overall Width                 | 1.73m           |
|  | C Overall Height                | 1.99m           |
|  | Platform Size                   | 1.45m x 0.76m   |
|  | Ground Clearance                | 0.20m           |
|  | B Wheel Base                    | 2.00m           |
|  | Turning Radius (Inside/Outside) | 2.08m/3.30m     |
|  | Turret Rotation                 | ±180°continuous |
|  | Platform Rotation               | 160°            |
|  | Jib Movement                    | +70°/-60°       |
|  | Batteries                       | 8x6V/420Ah      |
|  | Integrated Charger              | 48V/25A         |
|  | Drive Motor                     | AC 48V/3.3kW    |
|  | Lifting Motor                   | 48V/4.5kW       |
|  | Travel Speed (Stowed)           | 6.1km/h         |
|  | Travel Speed (Working)          | ≤0.5km/h        |
|  | Gradeability                    | 30%             |
|  | Maximum Slope                   | 3°              |
|  | Hydraulic Tank                  | 30L             |
|  | Tyre                            | 17.5 x 6.75     |
|  | Gross Weight                    | 6550kg          |

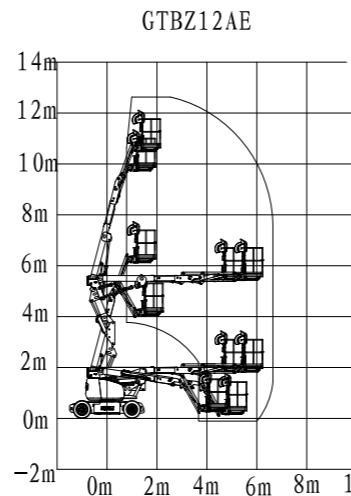

### Standard Equipment

- Proportional Controls
- Manual Safety Pump
- Hour Meter
- Tilt Sensor
- 360° Turntable Rotation
- Self-leveling Platform
- Deadman
- Foam-filled Tyres
- 4X2 AC Drive
- Onboard Diagnostic System
- All Motion Alarm
- Horn
- Flashing Beacon
- Zero Emission



Gradeability



Manual Safety Pump



Waterproof Platform Control



Batteries