

Dingli Boom Lifts Product Manuals



Electric



Engine



DINGLI[®]

Exceed · New Height



Dingli Self-propelled Boom Lifts Are Divided Into Telescopic Boom Lifts And Articulating Boom Lifts, With Two Types Driving Mode Of **Electric Drive** And **Engine Drive**. There Are 14 Models In The Whole Series, Including 10 Telescopic Boom Lifts And 4 Articulating Boom Lifts, With Working Heights Ranging From 24.3m To 30.3m. The Whole Series Is Jointly Developed By Dingli And Italian Research And Development(R&D) Center, With Completely Independent Intellectual Property Rights.

The Whole Series Of Boom Lifts' Counterweight And Center Of Gravity Move Down, Adopts The Whole Components To Move Down Design, Inherits The Family Modular Concept, Relies On The Performance Guarantee Of A Series Of High-end Configuration Such As American DANA Spicer Axle, Germany Bosch Rexroth High Pressure Driveline System And Danish Danfoss PVG Hydraulic Control System, Which Are The World's Leading Technology. They Have Many Advantages Such As Heavy Load, Strong Power, High Chassis, Easy Maintenance, Easy Transportation, Stable Control, Safer, **High Energy Saving**, **Great Endurance Ability**, **More Environmentally Friendly**, Etc., And Can Be Competent For All Kinds Of Complex And Severe Limit Working Conditions!

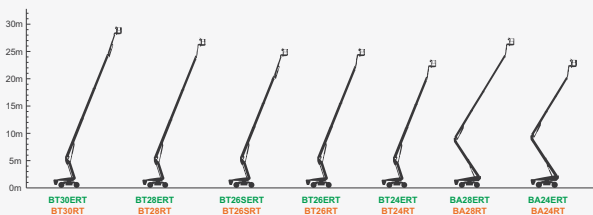

**Heavy Load**

The Whole Series Of Telescopic Boom Lifts Max. Load 454kg (Full Height Travel), Articulating Boom Lifts Max. Load 300kg (Full Height Travel), The Load Capacity Is Greater.

**High Chassis**

The Whole Series Is Equipped With Large Wheel Hub, Tire Diameter Of 108cm, Chassis Clearance Of 41cm, Compared With The Traditional Boom Lifts, Better Passability.

**Strong Power**

Equipped With A Special Axle For Aerial Working Platforms, It Can Meet The Requirements Of 4WD, And The Gradeability Is Up To 45% (Engine Type); Equipped With 100% Hydraulic Differential Lock System, Even If Three Wheels Slip, Start Differential Lock System Can Still Go Forward, Rough-terrain Performance Is Stronger.

**Great Endurance Ability**

The Electric Type Whole Series Is Equipped With 520Ah/80V High-capacity Lithium Battery, With Greater Endurance Ability.

**Easy Maintenance**

The Whole Series Adopts The Family Modular Design, 95% Main Components Are Common, More Than 80% Structural Parts Are Common. Only Need To Repair 1 Model, The Whole Series Of Models Are Covered; Only Need To Purchase 1 Set Of Components, The Whole Series Of Models Are All Universal. The Electric Model Is Equipped With A Five-year Warranty Without Maintenance Lithium Battery, Which Greatly Reduces The Cost Of Engine Maintenance And Diesel Addition.

**Stable Control**

The Whole Series Adopt The Whole Component To Move Down Design, The Center Of Gravity Is Lowered, Cooperate With The Special Intelligent Control System, Making The Whole Machine More Stable, The Operation Is More Stable.

**Easy Transportation**

The Whole Series Not Only Can Be Transported By Basic Flatbed Truck, But Also Can Be Shipped In Regular Container (40HQ).

**High Energy Saving**

The Engine Type Is Equipped With ECO Green Energy Saving System, Which Can Control Engine Speed Intelligently, Supply Oil On Demand, Heat Dissipation According To Temperature, And Save Energy.





**More environmentally friendly**

The Full Range Of Electric Models Are Equipped With Dedicated Electric Drive Axles, Using Batteries As The Power Source, With Low Noise, Zero Emissions, No Pollution, And More Environmentally Friendly.

**Safer**

The Whole Series Is Equipped With The Dual Sensing System, Intelligent Anti-extrusion System, Intelligent Safety Valve Protection System, Etc. Which Is More Secure. The Boom Uses Q960 Special Steel, The Safety Is Higher. The Maintenance-free Lithium Battery Of The Electric Type Is Equipped With BMS Battery Management System To Ensure The Equipment Electricity Safety.

**The Gradeability Up To 25%****Anti-extrusion Device****100% Hydraulic Differential Lock System**
Three Wheels Slip, Can Still Go Forward**High-capacity Lithium Battery Pack****Multiple Steering Modes**

Model	 =Electric  =Engine	BT28ERT	BT28RT
Type	Telescopic Boom Lifts		
Size			
Max. Working Height	28.60m		
Max. Platform Height	26.60m		
Max. Horizontal Reach	21.30m		
Overall Length(Stowed) A	11.66m		
Overall Length(Transport)	11.82m		
Overall Width(Stowed) B	2.50m		
Overall Width(Transport)	2.28m		
Overall Height(Stowed) C	2.89m		
Overall Height(Transport)	2.57m		
Platform Size(Length×Width)	2.44m×0.9m		
Turntable Tailswing	1.61m		
Ground Clearance D	0.41m		
Wheelbase E	2.8m		
Turning Radius(Inside/Outside)	1.87m/3.22m		
Tyres	385/45-28		
Up And Over Clearance			
Max. Down Probing Depth			
Performance			
S.W.L(Unrestricted/Restricted)	300kg/454kg		300kg/454kg
Max. Occupants	3		
Gradeability	30%		45%
Travel Speed(Stowed)	6km/h		
Travel Speed(Raised)	1.1km/h		
Max. Working Slope	X-5°/Y-5°		
Turret Rotation	360°Continuous		
Platform Rotation	180°		
Jib Movement	135°		
Weight			
Overall Weight	18400kg		
Power			
Power Source	 Lithium Battery 520Ah/80V Charger 5kW/80V,12V		 Diesel Engine Deutz TD2.9 L4 55.4kW
Hydraulic Oil Tank	165L		

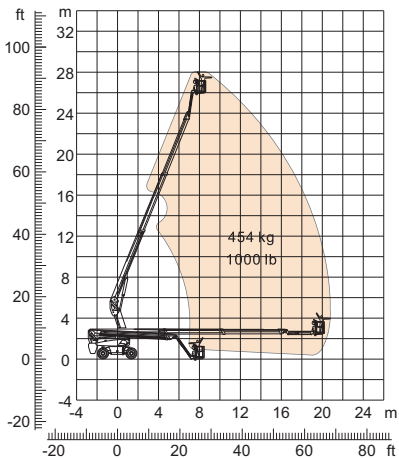

BT28ERT



BT28RT

