

Dingli Vertical Lifts Product Manuals

 Electric

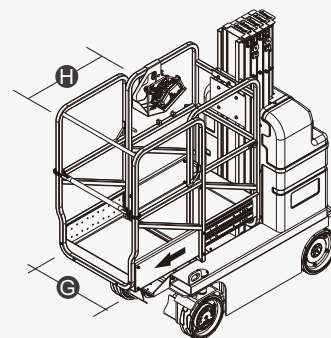

DINGLI®
Exceed · New Height

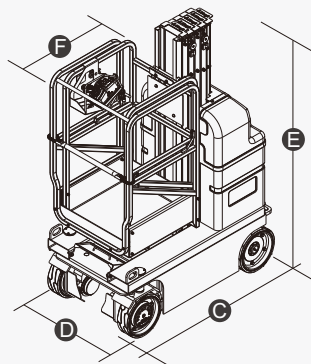
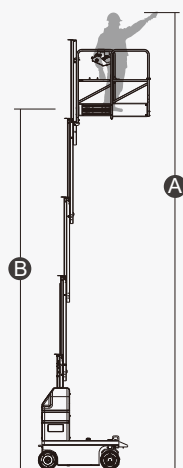

Self-propelled Vertical Lifts

PARAMETER

Model	AMWP8-1200
S.W.L	159kg
Max. Occupants	1
Max. Working Height (A)	8.00m
Max. Platform Height (B)	6.00m
Overall Length (C)	1.39m
Overall Width (D)	0.80m
Overall Height (E)	1.99m
Platform Size(Length (F) /Width (G))	0.73m×0.75m
Platform Extension Size (H)	0.53m
Ground Clearance(Stowed)	0.06m
Ground Clearance(Raised)	0.019m
Wheelbase	1.07m
Turning Radius(Inside/Outside)	0/1.55m
Drive Motor	2×24VDC/1kW
Lifting Motor	24VDC/2kW
Travel Speed(Stowed)	4km/h
Travel Speed(Raised)	1.1km/h
UP/Down Speed	23/25sec
Batteries	2×12V/115Ah
Integrated Charger	24V/15A
Gradeability	25%
Max. Working Slope	X-1.5°/Y-3°
Tyres	Φ323×100mm
Weight	1120kg

Standard Equipment

Cylinder Holding Valve
 Emergency Stop Button
 Two Controllers Operation
 Emergency Lowering System
 Leveling Sensor
 Forklift Pockets
 All Motion Alarm
 Transport Tie Hole
 Battery Charge Indicator
 Electric Limit Switch
 Automatic Pothole Protection
 Drivable At Full Height
 Overload Sensor With Alarm
 Onboard Diagnostic System
 Flashing Beacon

Options

AC Power to Platform

